

# 一体机自动吸风剪线说明书 (V:3.05)

ALL-IN-ONE AUTO TRIMMER AND SUCTION MANUAL BOOK(V:3.05)

## 前言

## Preface

欢迎使用本公司产品，制衣行的正确投资选择！

Welcome to use the our products, it is the right investment choices in garment industry!

本说明书为本公司新研发的“一体机自动吸风剪控制箱”产品参考手册，请认真阅读此手册以更好的运用本公司产品！

This user manual is for our newly developed “All-in-one control box” products reference manual, Please read this manual carefully, hope it can give you useful help!



阅读本说明前以下要求说明请注意

Before reading the manual, please note the following requirements:

1: 用户使用作业前必须可靠接地，保证人生安全！

The user must be reliably grounded before operating to ensure the safety of life!

2: 非专业人士请勿拆卸控制箱

Non-professionals do not disassemble the control box

3: 控制箱与电机远离强磁高辐射环境

The control box and motor away from the magnetic high radiation environment

4: 不要在过热环境中作业（请在室温 5° C 以上、45° C 以下的场所操作）

Do not work in hot environment (Please operate at room temperature above 5 °C and below 45 °C)

5: 不要在过于潮湿环境中作业（请保持 30 % ~ 95 % 相对湿度（无凝露）

Do not work in humid environments (Please maintain 30% ~ 95% relative humidity (no condensation))

6: 供电电压范围如下：

The supply voltage ranges are as follows:

**220V 电控：【220V 接入供电时电压稳定在（AC200V~240 单相）之间】**

220V control box: [220V access power supply voltage stability in (AC200V ~ 240V single-phase) ]

电源供电电压 Power supply Voltage	220V±15%	单相 single phase
频率 Frequency	50~60HZ	
电机转速 motor speed	200-6500RPM	
电机扭矩 motor torque	≤2.2N.M	

**110V 电控：【110V 接入供电时电压稳定在（AC100V~130/单相）之间】**

110V control box: [110V access power supply voltage stability in (AC100V ~ 130V single-phase) ]

电源供电电压 Power supply Voltage	110V±15%	单相 single phase
频率 Frequency	50~60HZ	
电机转速 motor speed	200-6500RPM	
电机扭矩 motor torque	≤2.2N.M	

安全叮嘱：

**Safety requirement:**

1: 电机电控接通电源时（开机状态）请不要把脚放在脚踏板上

Do not put your feet on the pedals when the control box and motor is switched on (boot status)

**2: 本产品请专业人士安装调试**

Let professionals to install and debug this product

**3: 严禁在通电时打开控制箱与电机端盖**

Do not open the control box and the motor cover when energized

**4: 换针, 穿线或更换底线时请关闭电源**

Please turn off the power when changing the needle,threading or replacing the bottom line

**5: 安装, 拆卸维修时请拔掉电源插头**

During installation and removal service,please turn off the power and pull the plug

**6: 翻抬缝纫机时请关闭电源**

Please turn off the power when turn lift sewing machine

**7: 使用本产品请远离高频电磁波和电波发射器等, 以免所产生的电磁波干扰伺服驱动器而发生错误动作。**

When use this product, please stay away from high-frequency electromagnetic waves and radio wave transmitters, etc., in case the electromagnetic waves generated interfere with the servo drive to occur wrong action .

**8: 禁止在日光直接照射的场所或室外运作**

Do not operate in direct sunlight or outdoors

**郑重声明:**

**Solemnly Declare:**

**1: 不遵守安全使用说明操作规章, 发生意外后果自负。**

Do not comply with the manual book operating regulations and the safety requirements, all accidental occurrence should be taken by yourself.

**2: 未经本公司授权, 请勿擅自改动产品, 由此而引起的后果本公司不负任何责任。**

Without our authorization, please do not alter our products, our company is not liable for any consequences arising therefrom.

**保修策略:**

**1: 本产品自购买起免费保修\_\_年, 终身维护。保修期内除人为损坏外出现的任何质量问题可免费修**

Since from the purchase of this product,the free 2-year warranty,lifetime maintenance. During the warranty period,any quality problems the product will be free repaired,except artificial damage.

**2: 未经本公司同意自行拆卸, 改装造成损坏将不给予保修**

Without our consent disassemble or modify,the damaged will not give in warranty.

**3: 但凡出现无法解决的问题可以联系本公司**

Whenever find the problem can not be solved,you can contact with our company.

# 目录

## Contents

### 1:显示屏常用操作介绍

Introduction of display screen common Operation

### 2:如何进入参数与如何修改参数

How to enter parameters and how to modify the parameters

### 3:控制箱端口说明

The control box Port Description

### 4:错误代码解析

Error code analysis

# 1: 显示屏常用操作介绍 Introduction of display screen common Operation

1.1、显示屏介绍：它由两大部分组成（显示区域、操作界面）。

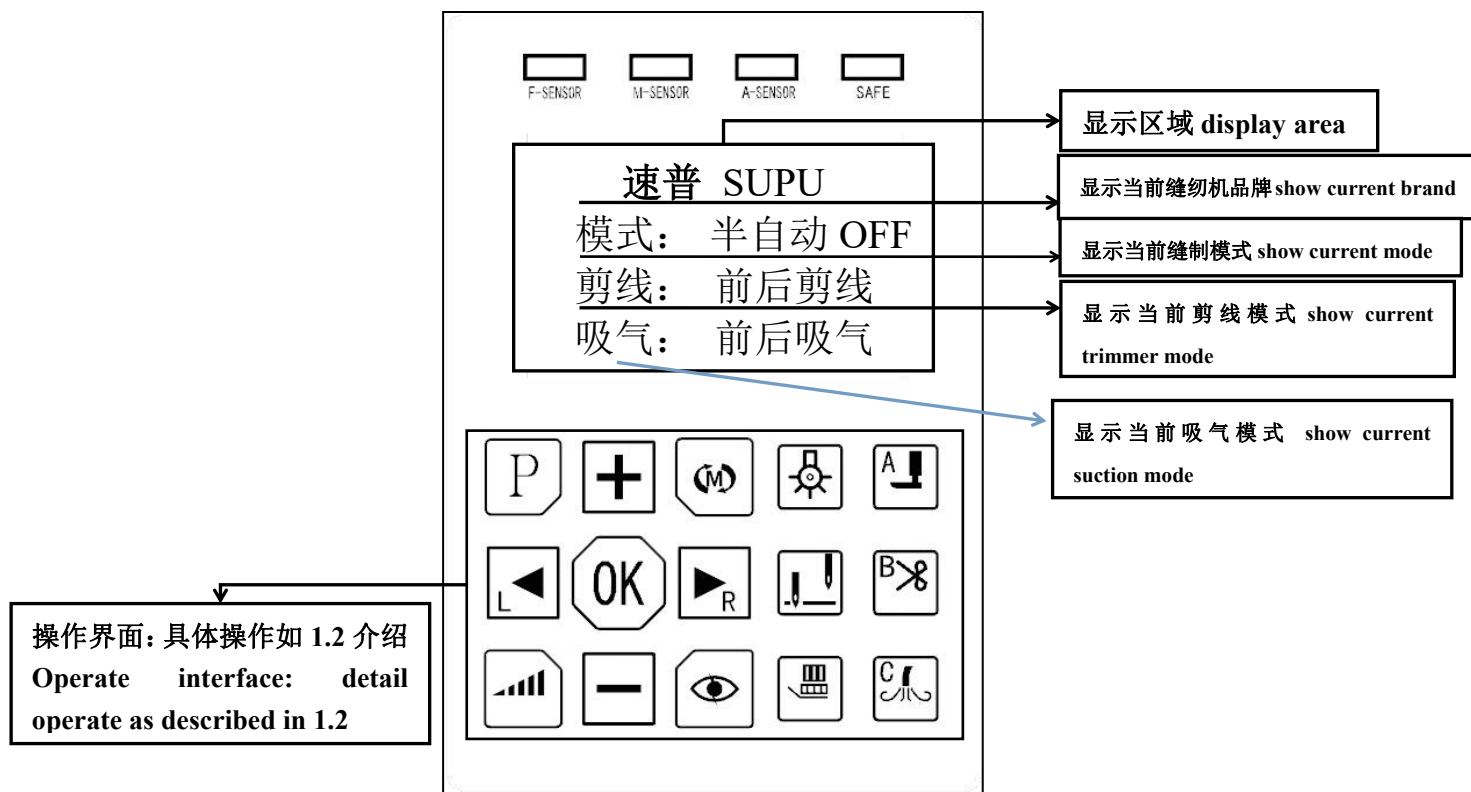

1.1、 the display screen introduction: it consists of two major components (display area, operate interface) .

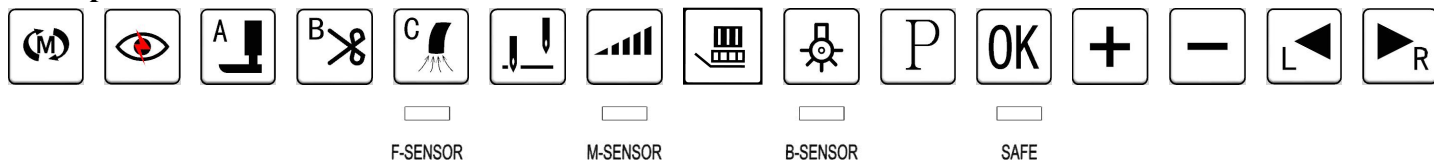

1.2、操作界面功能键介绍:

Operate interface function introduction:







序号 serial number	按键图标 Parameters of the code	功能说明 function instruction
1	 (模式切换键) (Mode transfer switch)	<p>点键: 全手工→自由缝→半自动→全自动, 之间切换;</p> <p>全自动: 当布料盖住第一光眼时, 机器会自动启动工作不需用脚去踩踏调速器踏板;</p> <p>半自动: 布料遮住第一光眼, 脚踏调速器才能驱动机器工作;</p> <p>自由缝: 无布料遮住第一光眼, 脚踏调速器一样也能驱动机器工作;</p> <p>全手工: 剪线、抬压脚等所有动作需要人工去完成;</p> <p>※:全自动、半自动、自由缝等安全开关断开情况下脚踏调速器无法驱动机器工作;</p> <p>全手工: 安全开关断开情况下一样能使用脚踏调速器启动机器工作)。</p> <p>Pressbutton: between full manual→free sewing→half-auto→full-auto to transfer;</p> <p>Full-auto: when the cloth cover the first sensor, the machine will be working</p>





automatically, no need to press the pedal;  
**Half-auto:** when the cloth cover the first sensor, need to press the pedal to drive the machine to working ;  
**Free-sewing:** if no cloth cover the first sensor, press the pedal, the machine is still can work;  
**Full manual:** thread cutting、presser foot lifter and other function should be finished by hand;  
 ※: The pedal can not drive the machine when the safety switch is off under the mode of full-auto, semi-auto, free sewing...  
 Full manual: The pedal still can drive the machine when the safety switch is off.

长按模式键（需要密码）：  
 S28 光眼模式 2  
 S29 前光眼极性 0  
 S30 后光眼极性 0  
 S35 后光眼开启 2  
 S43 网孔针数 06  
 Long press mode button(need code):  
 S28 sensor mode 2  
 S29 front sensor polarity 0  
 S30 back sensor polarity 0  
 S35 back sensor open 2  
 S43 net hole stitches 06













2



































1. 如何进入布料选择：点动键时进入布料选择;A:厚料、B:普通、C:薄料、D:透明、E:大网、F:小网；（选择厚料、普通、薄料时可以使用快捷按键（  ），也可以使用上下左右移动键选择布料模式，选择好布料按键确认并退出布料选择）。

How to enter into cloth choice: press  to enter into the cloth choice; A:heavy material B:normal material C:light material D:see through material E:big net F: small net ;(we can use quick button (   )to choose heavy material、normal material、light material. can also use the up, down, left, and right buttons to select the cloth mode, when finish press  button to confirm and exit cloth choice.)



2. 如何进入光眼微调：在布料选择页面时，点动键进入当前光眼灵敏度和微调灵敏度参数；

		<p>如何进入光眼粗调：在布料选择页面时，按一下  键、此时会出现“**** 布料选择****”，点动  键进入当前光眼灵敏度和微调、粗调灵敏度参数；</p> <p>How to enter into sensor fine-tuning: On the cloth selection page, click  to enter the current sensor sensitivity and fine-tuning sensitivity parameters; how to enter sensor coarse-tuning: on the cloth selection page, press the  button, and " * * *cloth selection* * * " appears, click the  key to enter the current sensor sensitivity and fine-tuning, coarse-tuning sensitivity parameters;</p>																																	
3	 (压脚功能键) (Presser foot switch)	<p>点动  键时进入压脚调整，重复点动切换：前抬压脚，后抬压脚，前后抬压脚，抬压脚关闭，</p> <p>Press  to switch presser foot sensor in turn :front lift, rear lift, front rear and off lift.</p>	<p>长按  键进入压脚参数调整（需密码：2014）：</p> <p>Long press  to adjust presser foot parameters (password required)</p> <table border="0"> <tr><td>S19 前抬压脚保留时间</td><td>0220</td></tr> <tr><td>S20 后抬压脚延迟启动</td><td>0000</td></tr> <tr><td>S21 抬压脚保留时间</td><td>006</td></tr> <tr><td>S22 放压脚保护时间</td><td>020</td></tr> <tr><td>S31 压脚全力时间</td><td>180</td></tr> <tr><td>S32 压脚全力功率</td><td>100</td></tr> <tr><td>S33 压脚保持功率</td><td>20</td></tr> <tr><td>P22 关闭手动抬压脚</td><td>0</td></tr> <tr><td>S19 front foot presser lift retaining time</td><td>0220</td></tr> <tr><td>S20 back foot presser lift start time</td><td>0000</td></tr> <tr><td>S21 foot presser protection time</td><td>006</td></tr> <tr><td>S22 release foot presser protection time</td><td>020</td></tr> <tr><td>S31 foot presser full power time</td><td>180</td></tr> <tr><td>S32 foot presser full power</td><td>100</td></tr> <tr><td>S33 foot presser retaining power</td><td>20</td></tr> <tr><td>P22 close manual foot presser lift</td><td>0</td></tr> </table>	S19 前抬压脚保留时间	0220	S20 后抬压脚延迟启动	0000	S21 抬压脚保留时间	006	S22 放压脚保护时间	020	S31 压脚全力时间	180	S32 压脚全力功率	100	S33 压脚保持功率	20	P22 关闭手动抬压脚	0	S19 front foot presser lift retaining time	0220	S20 back foot presser lift start time	0000	S21 foot presser protection time	006	S22 release foot presser protection time	020	S31 foot presser full power time	180	S32 foot presser full power	100	S33 foot presser retaining power	20	P22 close manual foot presser lift	0
S19 前抬压脚保留时间	0220																																		
S20 后抬压脚延迟启动	0000																																		
S21 抬压脚保留时间	006																																		
S22 放压脚保护时间	020																																		
S31 压脚全力时间	180																																		
S32 压脚全力功率	100																																		
S33 压脚保持功率	20																																		
P22 关闭手动抬压脚	0																																		
S19 front foot presser lift retaining time	0220																																		
S20 back foot presser lift start time	0000																																		
S21 foot presser protection time	006																																		
S22 release foot presser protection time	020																																		
S31 foot presser full power time	180																																		
S32 foot presser full power	100																																		
S33 foot presser retaining power	20																																		
P22 close manual foot presser lift	0																																		
4	 (剪刀功能键) (Trimmer switch)	<p>点动  键时进入剪线调整，重复点动切换：前剪线，后剪线，前后剪线，</p>	<p>长按  键进入剪线参数调整：</p>																																

		<p>剪线关闭,</p> <p>Press  to switch cutter sensor in turn:front cutting,rear cutting ,fro+rear cutting and off cutting.</p>	<p>Long press  to adjust trimmer parameters.</p> <p>S03 前剪线延迟针数 22  S04 后剪线延迟针数 06  S24 手剪线 1  S25 安全开关 3  S26 切刀保留时间 25</p> <p>S03 Delay stitch number to cut thread after front sensors 22  S04 Delay stitch number to cut thread after three sensors 06  S24 operate manual switch action 1  S25 safe switch choice 3  S26 the knife retaining time 25</p>
5	<p>  (吸风功能键)  (Trimmer switch)</p>	<p>点动  键时进入吸风调整,重复点动切换:前吸气,后吸气,前后吸气,吸气关闭,</p> <p>Press  to switch suction device in turn:front suction,rear suction,fro+rear suction and off suction.</p>	<p>长按  键进入吸风参数调整:</p> <p>Long press  to adjust parameters of suction device.</p> <p>S05 前吸延迟开启针数 02  S06 前吸气关闭针数 14  S07 后吸气延迟开启针数 02  S08 后吸气延时关闭 0200  S13 中吸气延时开启针数 050  S14 中吸气关闭针数 020</p> <p>S05 Delay stitch number for starting front air suction 02  S06 Front suction close stitches no 14  S07 back suction start stitches no 02  S08 the delay of back suction close 0200  S13 middle suction start stitches no 050  S14 middle suction close stitches no 020</p>
6	<p>  (停针位调整键)  (Stop pin position adjustment button)</p>	<p>点动  键时切换上针位、下停针位和下针位不回针</p> <p>Press  to switch up or down stop pin position.</p>	<p>长按  键进入针位参数调整:</p> <p>Long press  to adjust pin position parameter.</p> <p>S02 两传感器间针数 20  S12 停车延迟针数 02</p> <p>S02 Stitch number between two sensors 20</p>



		S12 machine stop delay stitches no 02	
7	 (速度调整键) (Speed adjustment button)	<p>点动  键进入转速调整，再通过 、 键调整需要的转速，转速自动保存。</p> <p>Press  to enter speed parameter and press 、 to change the speed value (value automatically saved)</p>	<p>长按  键进入转速锁定（需要密码）</p> <p>Long press  to lock speed parameter (password required)</p>
8	 (松线功能调整键)	<p>点动  键进入松线模式调整，重复点动切换：前松线、后松线、前后松线、松线关闭。</p>	
9	 (机头灯调整键) (Machine LED button)	<p>点动  键时进入机头 LED 灯亮度调节（1-5 挡）</p> <p>Press  button to enter into the adjustment of the LED light (1-5 degree)</p>	<p>长按  键进入参数调整：</p> <p>Long press  to adjust parameter.</p> <p>P13 工作亮度 4 P14 背光亮度 0 P13 the degree of the working LED light 4 P14 the backlight degree 0</p>
10	 (菜单键) (Menu button)	<p>点动进入用户参数 Press to enter user parameters</p>	<p>长按进入系统参数（需要密码） Long press to enter system parameters (password required)</p>
11	 (确认键) (Confirm button)	<p>参数确定键 Parameter confirm button</p>	
12	 (数值调整键) (Numerical adjustment key)	<p>向上键（修改数据时加） Up key (when increasing value)</p>	
13	 (数值调整键) (Numerical adjustment key)	<p>向下键（修改数据时减） Up key (when increasing value)</p>	





14	 (左移键) (Filter key)	向左键 (在进入参数项时光标向左移) Left key (when adjusting items)	
15	 (右移键) (Filter key)	向右键 (在进入参数项时光标向右移) Left key (when adjusting items)	
16	F-SENSOR	前光眼指示灯 Front sensor indicator	当光眼被挡住时, 此灯亮、未挡住时不亮; 如未被挡住时, 此灯亮起; 则需要检查光眼灵敏度。 When the sensor is blocked, the light will be on, when it is not blocked, the light is not on ; if it is not blocked, the light is on; the sensor sensitivity needs to be checked.
17	M-SENSOR	中光眼指示灯 Medium sensor indicator	当光眼被挡住时, 此灯亮、未挡住时不亮; 如未被挡住时, 此灯亮起; 则需要检查光眼灵敏度。 When the sensor is blocked, the light will be on, when it is not blocked, the light is not on ; if it is not blocked, the light is on; the sensor sensitivity needs to be checked.
18	B-SENSOR	后光眼指示灯 Back sensor indicator	当光眼被挡住时, 此灯亮、未挡住时不亮; 如未被挡住时, 此灯亮起; 则需要检查光眼灵敏度。 When the sensor is blocked, the light will be on, when it is not blocked, the light is not on ; if it is not blocked, the light is on; the sensor sensitivity needs to be checked.
19	SAFE	安全指示灯 Safety switch indicator	当安全开关断开时, SAFE 灯亮起时, 则检查一下安全开关是否感应到。 When the safety switch is off and the SAFE light is on, check that the safety switch is responsive.

## 2: 如何进入参数与如何修改参数 :

技术员系统参数列表如表 1:

2.1、长按 () 键持续 2 秒钟进入“系统参数”列表 (需要密码进入调整)。(  ) (  ) 键将选取修改







的是参数值还是菜单值, 点动后选取的地方将会出现闪烁。(  ) (  ) 键将增加或减少闪烁区的数值, 修

改完毕参数后需要按 (  ) 键保存参数并退出系统参数。

**注:** 以上是进入方法, 具体参数号代表的参数意思详情如下:

出厂值密码: 2014







## System parameter entering analysis:

2.1、Long press (  ) button for 2seconds to enter “System Parameter” list (requires a password to enter the adjustment). (  ) (  ) key to select to modify parameter value or menu value. Then, the selected value will be flashing. (  ) (  ) key to increase or decrease the value. After completing modification, press (  ) button to save parameters and quit system parameters.

※ Above is to enter method, the details of specific parameters describe as followings:

※ Factory default password:2014

## 工人参数列表如表 2:

2.2、点动  键直接进入参数， (  ) (  ) 键将选取修改的是参数值还是菜单值，点动后选取的地方将会出现闪烁， (  ) (  ) 键将增加或减少闪烁区的数值，修改完毕参数后需要按 (  ) 键保存参数并退出系统参数。

## 技术员系统参数列表:

表 1

序号 System parame ter list	功能说明 Function description	功能参数默认值 Parameter default values	功能参数范围 Parameter Adjustment range	参数说明 Parameter description
S01	针迹 Thread track	3	1~4	
S02	两传感器间针数 Stitch number between two sensors	20	1~50	设定两个光眼之间的针数 Set stitch number between two sensors
S03	前剪线延时针数 Delay stitch number to cut thread after front sensors	16	0~50	后面光眼感应到后延迟剪线的针数 Set delay stitch number after passing front sensors.Auto cut thread after stitches
S04	双光眼模式 后剪线延迟针数 Delay stitch number to cut thread after two sensors	06	0~50	后面光眼离开后延迟剪线的针数 Set delay stitch number after passing two sensors.Auto cut thread after stitches
	三光眼模式 后剪线延迟针数 Delay stitch number to cut thread after three sensors	16	0~50	
S05	前吸延迟气开启针数 Delay stitch number for starting front air suction	2	1~50	感应到第一个光眼后从第几针开始吸气 Set delay stitch number for starting front air suction after triggering first sensor
S06	前吸气针数	14	1~50	打开后，计数几针后关闭吸气

	Front suction close stitches no.			Account how many stitches begin to close former suction
S07	后吸延迟气开启针数 back suction start stitches no.	2	1~50	离开后光眼后第几针开始吸气 After leaving latter photo-eye,how many stitches begin suck
S08	后吸气延时关闭 the delay of back suction close	200	100~5000MS	离开光眼后,计数几毫秒后关闭吸气 After leaving latter photo-eyes,count how many milliseconds off suction
S09	前松线延迟开启针数 front thread loose delay	00		
S10	前松线针数 Front thread loose stitches	12		
S11	后松线延迟开启针数 Back thread loose start	00		
S12	停车延迟针数 machine stop delay stitches no.	2	1~99	剪完线后多少针自动停车 How much stitches auto parking after trimmer
S13	中吸气延迟开启针数 middle suction start stitches no.	50	1~250	中吸气间隔针数 middle suction interval stitches
S14	中吸气针数 middle suction close stitches no.	20	1~100	中吸气针数 Middle suction stitches
S15	后剪光眼(第三光眼)延迟检测针数 the needle no. of the delay of back cutting line	25	1~100	三光眼模式:布离开中光眼经过多少针后没检测到第三光眼信号就开始剪线 Leave in the light eye after much after the needle cannot detect the third eye signal begins to cut the line
S16	前传感器响应时间 front sensor respond time	100	1~100MS	前面光眼感应到后响应的的时间 The response time when former photo-eye sense
S17	前传感器灵敏度 front sensor sensitivity degree	55%	20~175	为适应不同布料设定前光眼的发射强度 Setting photo-eye through the fabric strength,to adapt to different fabrics
S18	后传感器灵敏度 Back sensor sensitivity degree	55%	20~175	为适应不同布料设定后光眼的发射强度 Setting photo-eye through the fabric strength,to adapt to different fabrics
S19	前抬压脚保留时间 front foot presser lift retaining time	220	100~2000MS	前光眼感应到布时压脚自动抬起维持时间 when front sensor feel the cloth, the foot presser lifter maintain time
S20	后抬压脚启动时间 back foot presser lift start time	0	0~2000MS	脚踏板后踏压脚响应的的时间(毫秒) The lift foot response time after latter foot pedal(millisecond)
S21	抬压脚保护时间 foot presser protection time	6	1~120S	手动抬压脚持续多少时间后自动关闭压脚输出(秒) Lifter the foot presser by hand some time then Auto close foot presser output(second)
S22	放压脚保护时间 release foot presser protection time	20	20~800MS	压脚释放保护时间(毫秒) the foot presser release protection time (millisecond)
S23	连续送布吸气剪线 continue feed cloth suction cutting line	0	0~1	0: 关闭 1: 开启 0:Close 1:Open

S24	运转中手动开关动作 operate manual switch action	1	0~3	0: 电机运转时按手动剪线不剪, 1: 运行中使能中光眼保护; 2: 运行中禁止中光眼保护; 3: 运行中后光眼保护 0:When the motor is running, tuch manual switch no cutting, 1:Have cutting
S25	安全开关选择 safe switch choice	3	0~7	0: 关闭安全开关; 1: 缝台安全开关; 2: 压脚安全开关 3: 缝台+压脚安全开关开启; 4.护目镜安全开关开启; 5: 缝台+护目镜安全开关开启; 6: 压脚壁+护目镜安全开关开启; 7.缝台+压脚臂+护目镜安全开关开启 0:off safety switch 1:Seam safety switch 2:Foot safety switch 3:
S26	切刀保留时间 the knife retaining time	25	1~1000MS	切刀动作时间(基本不用调整) Cutting action time (basically no adjustment)
S27	界面恢复时间 recover time	5	5~100S	控制面板在进入菜单后多少时间跳回主界面 After entering the control panel ,how much time to jump back to the main menu interface
S28	光眼模式(数量选择) sensor mode (number choice)	2	1~2	1:单光眼 2:双光眼 ※:第三光眼需要单独开启(S35) 1:single photo-eye 2:double photo-eye
S29	前光眼极性选择 front sensor polarity	0	0~1	反射光眼用 Opposite polarity opposite
S30	后光眼极性选择 back sensor polarity	0	0~1	反射光眼用 Opposite polarity opposite
S31	压脚全功率时间 foot presser full power time	180	10~990MS	压脚全功率工作时的时间 Time of full power operation
S32	压脚全功率时功率 foot presser full power	100	20~100%	压脚开始动作时, 瞬间的输出功率 When the foot starts to move, the instantaneous output power
S33	压脚保持功率 foot presser retaining power	20	10~90%	压脚抬起后维持住后的功率(不能超过 50)Pressure foot lift after the maintenance of the power to live (not more than 50)
S34	后剪光眼灵敏度(剪刀边上) 第三光眼 back cutting line sensor sensitivity degree	55	5~99%	第三光眼发射强度 the third sensor Emission intensity
S35	后剪光眼开启(剪刀边上) back cutting line sensor start	1	0~1	0: 关闭 1: 开启 0: closed 1: open
S36	预留 obligate	01		
S37	语言选择 language choice	0	0~2	0: 中文 1: 英文 2: 土耳其 3: 越南文 0:Chinese 1:English 2:英文 2: Turkish
S38	最大速度锁定 the max speed locked	5500	250~6500	电机的最大可调速度限制 Maximum adjustable speed limit for motor
S39	参数复位 parameter reset	0	0~1	调到 1 长按 OK 键有效 Transferred to 1 long-press the OK button to effective
S40	参数密码 parameter code	2014		注: 如记不住密码, 切记勿修改; 如修改密码忘记, 需寄回厂家从新解密。 Note: If you can't remember the password,

				don't change it. If you change the password and forget it, you need to send it back to the manufacturer for re-decryption.
S41	预留 reserve	2500	250-4500	
S42	预留 reserve	008	1-100	
S43	网孔针数 net hole stitches	06	0-15	网布的网孔不一样的需微调 it is need to adjust if the hole of the net is different
S44	布料选择 cloth choice	1	0-7	0:厚料 1:普通 2:薄料 3:透明 4:大网 5:小网 0:heavy material 1:normal material 2:light material 3:see through material 4:big net 5: small net
S45	前光眼动作阈值 front sensor action threshold value	50	5-200	
S46	中光眼动作阈值 middle sensor action threshold value	50	5-200	
S47	后光眼动作阈值 back sensor action threshold value	50	5-200	
S48	电机运转方向 motor running direction	1	0-1	0: 电机反转 1: 电机正传 0:counterclockwise 1:clockwise
S49	加速曲线 acceleration curves	70	10-100	
S50	加速灵敏度 acceleration sensitivity	6	1-6	
S51	光眼粗调启用 sensor rough adjust start	0	0-1	0: 关闭 1: 开启 0: closed 1: open
S52	强制自动剪线 force auto thread cutting	4	0-4	0:剪线最强保护 1:剪线强保护 2:剪线一般保护 3:剪线弱保护 4:剪线无保护 0:strongest protection 1: stronger protection 2:normal protection 3: weak protection 4:weakest protection
S53	光眼感应时间 sensor induction time	6	3-150	
S54	光眼解除感应时间 sensor cancel induction time	20	3-150	

## 工人系参数列表:

表 2

序号	功能说明	功能参数默认值	功能参数范围	参数说明
P-01	操作模式 Operate mode	0	0~1	0: 半自动 1: 全自动 0: semi automatic 1: fully automatic
P-02	电眼开关 sensor switch	1	0~1	0: 关闭 1: 开启 0:Closed 1:Open
P-03	剪线 cutting line	3	0~3	0: 关闭 1: 前剪线 2: 后剪线 3: 前后剪线 0: close 1: before the cut line 2: after the cut line 3:

				before and after the shear line
P-04	吸气 suction	3	0~3	0: 关闭 1: 前吸气 2: 后吸气 3: 前后吸气 0: closed 1: before the inspiration 2: after the inspiration of 3: before and after the inspiration
P-05	后拉布轮 back pulley wheel	0	0~2	0: 关闭 1: 缝制中 2: 缝制后 0: close 1: sewing in 2: after sewing
P-06	压脚 foot presser	3	0~3	0: 无抬压脚 1: 前抬压脚 2: 后抬压脚 3: 前后抬压脚 0: no lifting of the foot 1: front lifting foot 2: after the lifting of the foot 3: before and after the lifting of the foot
P-07	启动速度模式 start speed mode	1	0~1	0: 自动 1: 脚踏板 0: automatic 1: pedal
P-08	停车针位 needle positio	0	0~1	0: 上针位 1: 下针位 0: Upper pin position 1: a needle
P-09	停车自动抬压脚 machine stop auto foot presser lifting	0	0~1	0: 关闭 1: 开启 0: Closed 1: Open
P-10	手动吸气 suction by hand	1	0~1	0: 关闭 1: 开启 0: Closed 1: Open
P-11	启缝速度 start sewing speed	4800	200~5500	
P-12	最大速度 Max speed	5000	200~5500	
P-13	工作灯亮度 the degree of the working LED light	4	0~5	
P-14	背光灯亮度 the backlight degree	1	0~1	0: 关闭 1: 开启 0: Closed 1: Open
P-15	半自动连续缝制 semi-auto continue sewing	0	0~1	0: 关闭 1: 开启 0: Closed 1: Open
P-16	半自动恒速剪线 semi-auto constant sewing	0	0~1	0: 关闭 1: 开启 0: Closed 1: Open
P-17	前放压脚 front foot presser lift	0	0~1	0: 自动模式 1: 手工模式 0: automatic mode 1: manual mode
P-18	脚控剪线 foot controller cutting line	0	0~2	0: 关闭 1: 全手工 2: 自由缝半自动 0: closed 1: full manual 2: free stitch semi-automatic
P-19	中吸气 middle suction	1	0~1	0: 关闭 1: 开启 0: Closed 1: Open
P-20	半后踏抬压脚 half back foot resser lift	0	0~1	0: 关闭 1: 开启 0: Closed 1: Open
P-21	剪线后抬压脚 foot presser lift after cutting	0	0~1	0: 关闭 1: 开启 0: Closed 1: Open
P-22	关闭手动抬压脚 close manual foot presser lift	0	0~1	0: 关闭 1: 开启 0: Closed 1: Open
P-23	自由缝开启 start free sewing	0	0~1	0: 关闭 1: 开启 0: Closed 1: Open
P-24	后剪线光线延迟检测 back cutting line sensor	1	0~1	0: 关闭 1: 开启 0: Closed 1: Open

	delay check			
P-25	松线 thread tension releasing	3	0~3	0:关闭: 1: 前松线 2: 后松线 3: 前后松线 0: close 1: front thread tension releasing 2: back thread tension releasing 3: front and back thread tension releasing
P-26	自动跑合运行 auto running	0	0~1	0: 关闭 1: 开启 0:Closed 1:Open
P-27	自动跑合运行时间 auto runningn time	4	3~20	时间单位为: 秒 The time unit is: Second
P-28	自动跑合运行停止时间 auto running stop time	2	2~20	时间单位为: 秒 The time unit is: Second
P-31	音量调节 volume adjustment	020	025	参数播报语音
P-32	关闭开机语音 close the start voice	0	0~1	0: 关闭 1: 开启 0: close 1: open
P-33	网布模式 net mode	0	0-1	0: 关闭 1: 开启
P-34	禁止上停针 forbid upper needle stop	0	0-1	0: 关闭 1: 开启
P-35	剪线计数 Thread cutting count	0	0-9999	一个流程计数一次 The thread cutting count from first sensor to third sensor means one time

### 3: 控制箱端口说明

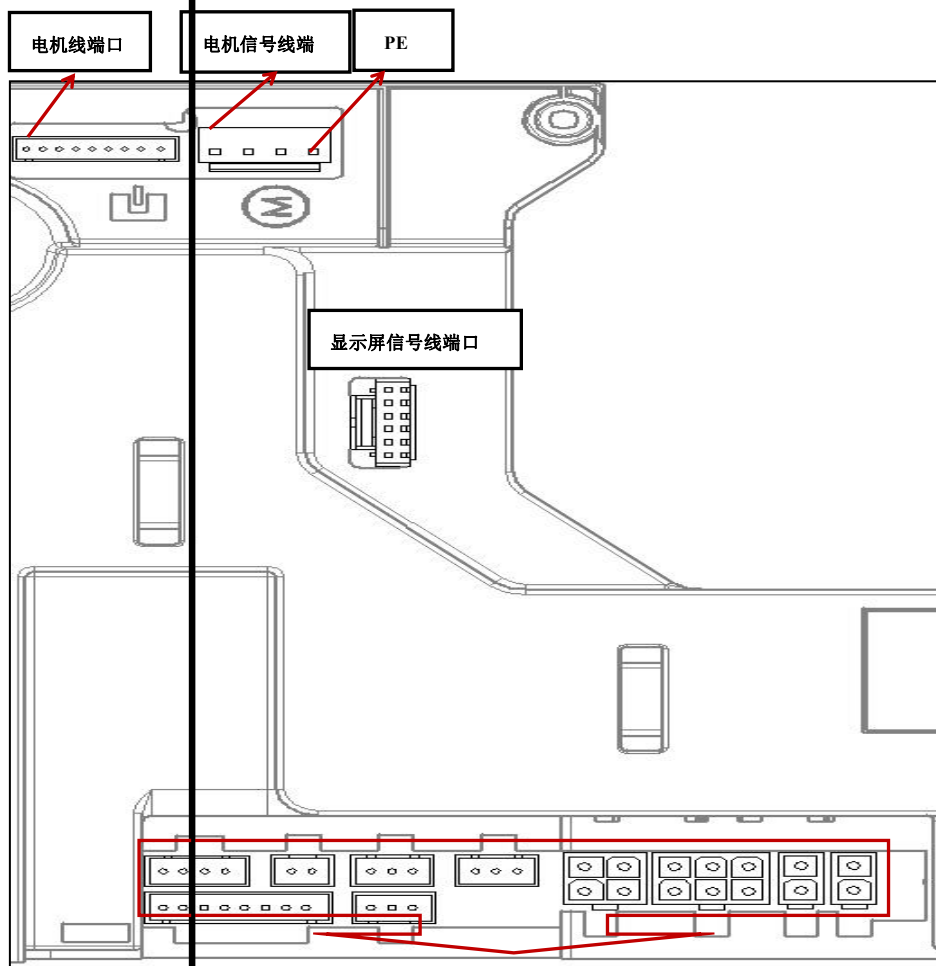

#### 3.1、端子插口说明:

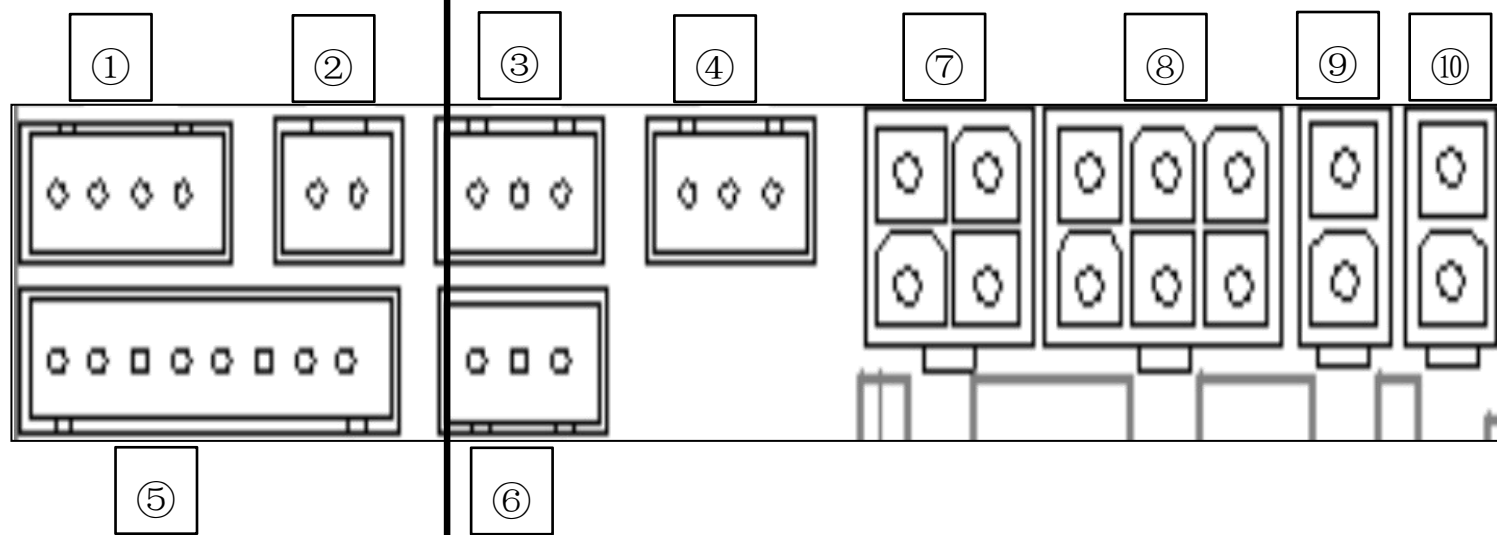

#### 下光线端口

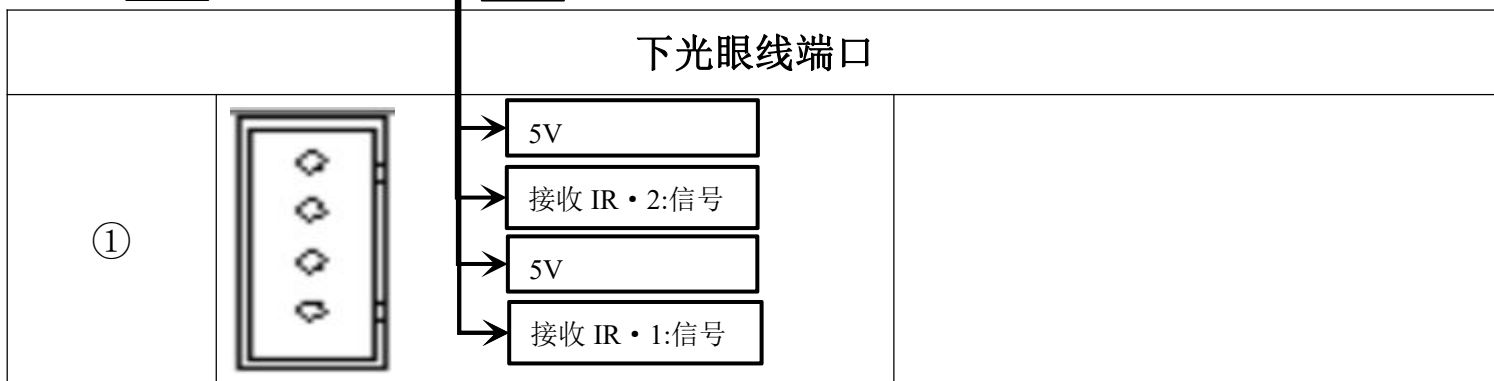



### 第三光眼线端口

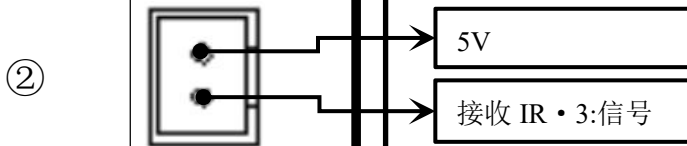

### 压脚壁安全开关线端口

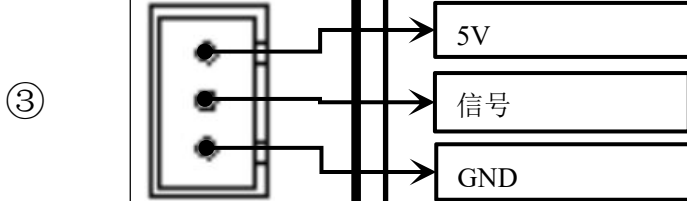

### 预留端口

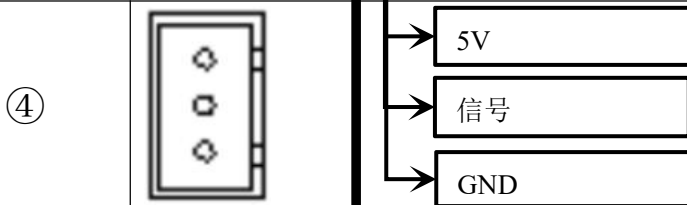

### 上光眼（一、二、三）和 LED 灯、剪线端口

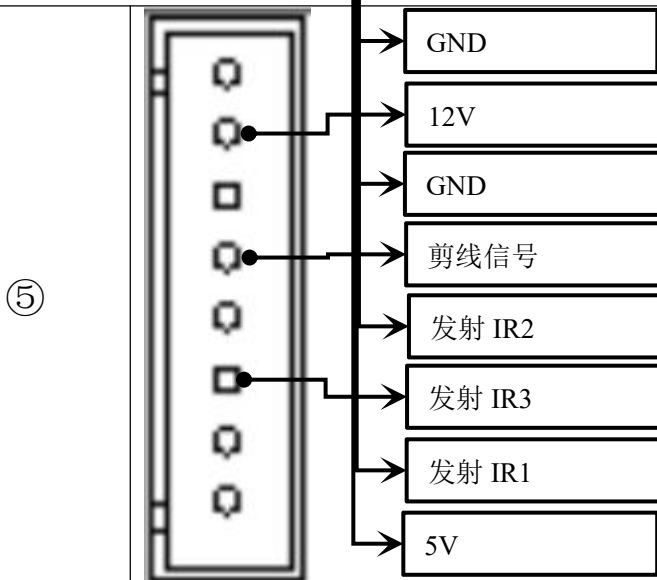

### 缝台安全开光线端口

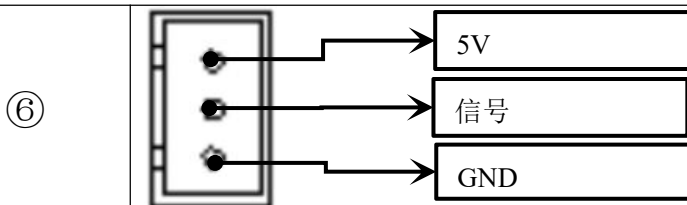

### 调速器线端口

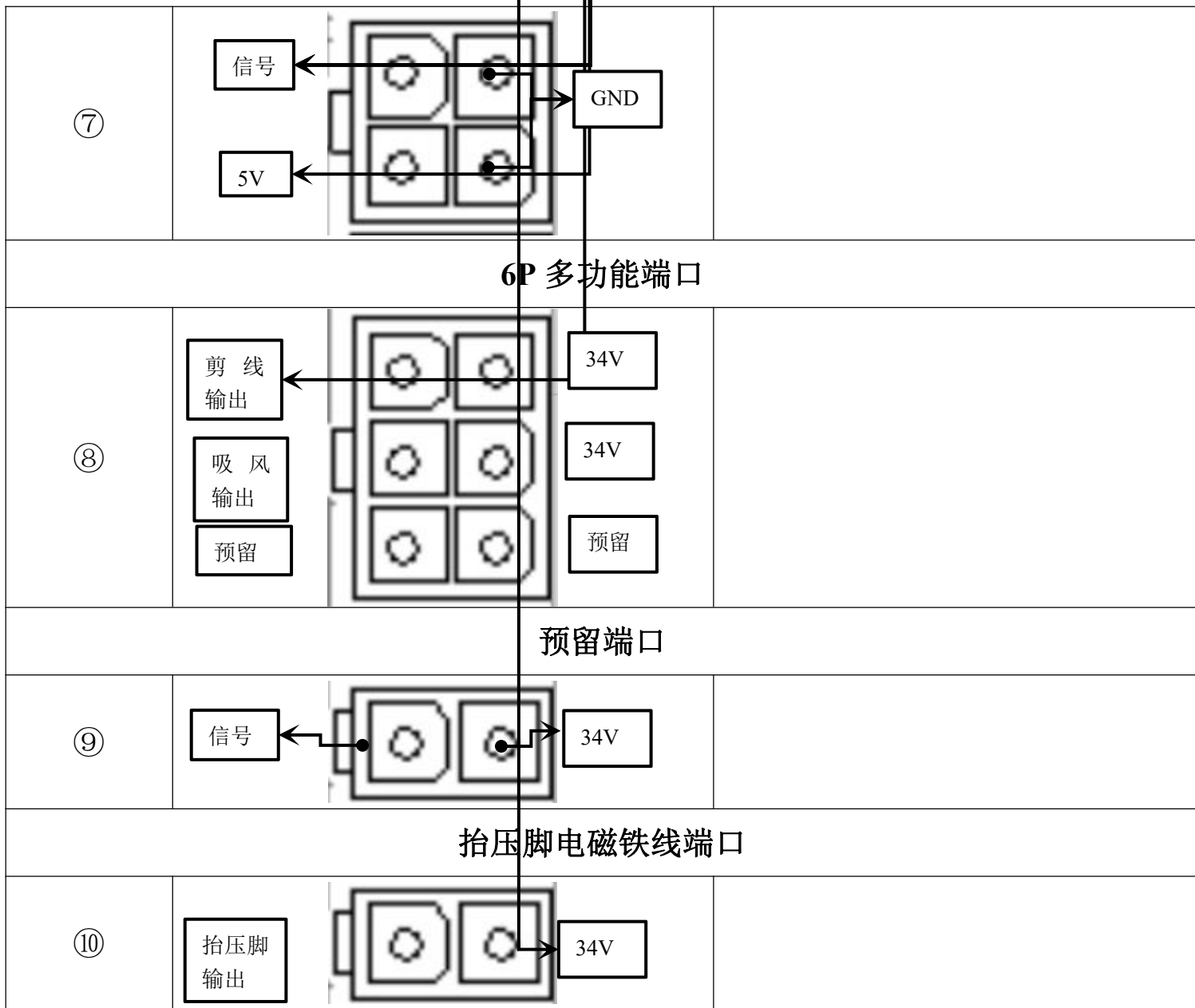

## 4: 故障代码解析

故障代码	故障描述	故障产生原因	故障的解决方法
ER-01	找不到停针位 not find needle position	1:手轮和电机靠的不够进 2: 手轮上磁钢脱落 3: 手轮磁铁极性装反 4: 九针端子头接触不良 5: 电机霍尔损坏 1: hand wheel and motor is not enough. 2: hand wheel steel shed 3: hand wheel magnet polarity 4: bad contact terminal nine 5: motor Holzer damage	1: 检查电机信号线有无松动 2: 更换手轮 3: 更换电机 1: check whether the motor signal line is loose 2:replace the wheel 3: replace the motor
ER-02	调速器信号错误 Foot controller signal error	1: 开机时没插调速器 2: 调速器插反 3: 调速器线断开 4: 调速器损坏	1: 检查调速器信号线 2: 更换调速器 3: 更换控制器 1: check the foot controller signal

		<p>1: start without connecting the foot controller</p> <p>2: Foot controller plug back</p> <p>3: the foot controller line is disconnected</p> <p>4: Foot controller damage</p>	<p>line</p> <p>2: change the foot controller</p> <p>3: replace the foot controller</p>
ER-03	<p>电机相位信号错误</p> <p>Motor phase signal error</p>	<p>1: 九针插头接触不良</p> <p>2: 电机安装时霍尔和转子存在大偏差</p> <p>3: 电机霍尔坏</p> <p>1: bad contact of nine pin plug .</p> <p>2: there is a large deviation in the installation of the motor Holzer and the rotor</p> <p>3: motor Holzer bad</p>	<p>1: 打开电机上的橡皮盖通过孔看电机转子与定子是否在同一平面保障误差 不超过 1MM</p> <p>2: 更换电机</p> <p>3: 更换控制器</p> <p>1: open the rubber cover on the motor through the hole to see whether the motor rotor and stator in the same surface to ensure the error is not more than 1MM</p> <p>2:replace the motor</p> <p>3: replace the controll box</p>
ER-04	<p>电机堵转保护</p> <p>Motor locked rotor protection</p>	<p>1: 缝纫机过重或堵死</p> <p>2: 电机过载</p> <p>3: 电机 4 线驱动线没连接好或插反</p> <p>1:sewing machine is overweight or blocked</p> <p>2: motor overload</p> <p>3: motor 4 wire drive line is not connected or inserted back</p>	<p>1: 检查电机 4P 线</p> <p>2: 检查缝纫机是否过重</p> <p>3: 更换控制器</p> <p>1: check motor 4P line</p> <p>2: check whether the sewing machine is too heavy</p> <p>3: replace the controller</p>
ER-05	<p>硬件过流保护</p> <p>Hardware overload protection</p>	<p>1: 缝纫机过重或堵死</p> <p>2: 电机过载</p> <p>3: 电机相位信号线没连接好</p> <p>1: sewing machine is overweight or blocked</p> <p>2: motor overload</p> <p>3: motor phase signal line is not connected</p>	
ER-07	<p>显示屏和主板通讯超时</p> <p>Serial communication timeout</p>	<p>1: 显示屏连接主板线连接不良</p> <p>2: 主板芯片损坏</p> <p>1: Connect error between display panel and mainboard</p> <p>2: motherboard chip damage</p>	<p>1: 检查显示屏与控制器连接线</p> <p>2: 检查控制器是否还可运行, 如不能运行就是控制器损坏</p> <p>3: 检查机器旁是否有高频机器干扰</p> <p>4: 更换显示屏</p> <p>1:Check the connection line between the display screen and the control box.</p> <p>2: check whether the controller run well, if not, controller damage</p> <p>3: check whether there is a high frequency machine near the machine interference</p> <p>4: change the display panel</p>
ER-09	<p>存储器不良</p> <p>memory error</p>	<p>1:主板存储器损坏或不良</p> <p>Memory on mainboard damage or error</p>	<p>1: 控制器损坏 1: control box damage</p>

ER-10	光眼控制线路故障 Sensor control line error	1:显示屏连接光眼线路不良 1:Connect error between display panel and sensor	1: 显示屏损坏 2: 显示屏背部光眼连接线接触不良 1: display panel damage 2: Connect error between display panel and sensor
ER-15	编码器故障 the motor board error		
ER-16	过压 Over load	<p>1: 电机驱动电源电压过高, 2: 220V 电源电压超过限定值 (AC310V), 或负载惯性过大导致再生电压超过限定值(DC440V),或电压检测回路故障。 注: (110V 控制系统电源电压超过限定值 (AC155V), 或负载惯性过大导致再生电压超过限定值(DC220V)).</p> <p>1. The motor drive power supply voltage is too high, the 220V power supply voltage exceeds the limit value(AC310V), or the load inertia is too large to the regenerative voltage exceeds the limit value(DC440V), or the voltage detection circuit fails.</p> <p>Note:(110V control system power supply voltage exceeds limit value(AC155V), or load inertia is too large to regeneration voltage exceeds limit value(DC220V).</p>	
ER-17	A 相电流检测故障 A current checking error		
ER-18	B 相电流检测故障 B current checking error		
ER-19	AB 相电流检测故障 A&B current checking error		
ER-20	欠压故障 Less volt error	<p>1.电机驱动电源电压过低, 220V 电源电压低于限定值 (AC91V), 或电机驱动电源电压低于限定值 (DC130V),或电压检测回路故障。 注: (110V 电源电压低于限定值 (AC45.5V), 或电机驱动电源电压低于限定值 (DC65V) )</p> <p>1. The motor drive power supply voltage is too low, the 220V power supply voltage is lower than the limit value(AC91V), or the motor drive power supply voltage is lower than the limit value(DC130V), or the voltage detection circuit fails.</p> <p>Note:(110 V power supply voltage is below the limit(AC45.5 V), or motor drive power supply voltage is below the limit(DC 65V))</p>	

版本号: V3.05

日期: 2020 年 10 月 03 日